

CIRCUIT DIAGRAM

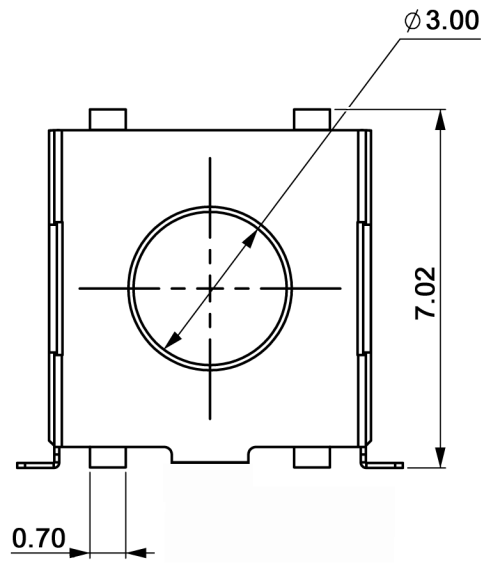

P.C.B. LAYOUT

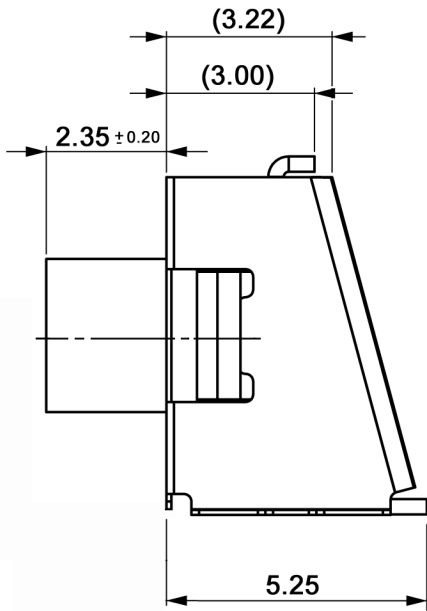
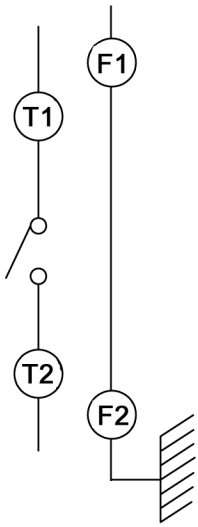
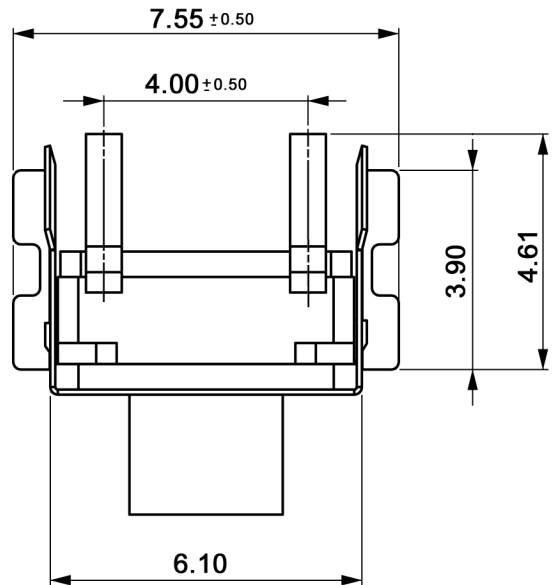
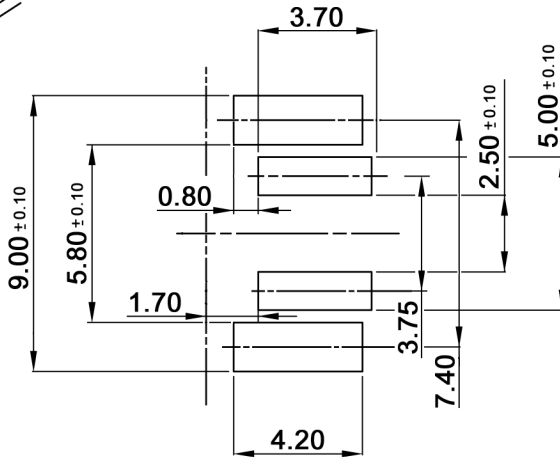

Specifications:

- Contact rating: 50mA, 12V DC
- Contact resistance: 100mOhm max.
- Insulation resistance: 100MOhm min. at 500V DC
- Dielectric strength: 250V AC (50Hz or 60Hz) for 1 minute
- Operating temperature: -25°C to +70°C
- Storage temperature: -30°C to +80°C
- Operating force: 260 +/-70g
- Mechanical life: 500 000 cycles
- Soldering temperature: max. 350°C, 5sec. max.
- Travel: 0.45 +/-0.2mm
- Material: Cover: nickel silver
Sealed rubber: silicone rubber hardness 70°-60°, red and brown
Contact: phosphor bronze, silver cladding
Terminal: brass, silver plated
Base: high-temp. thermoplastic PA9T UI94V-0, molded black



Tolerances: ±0.20mm	Date	Name
	01/06	dr
Travel	08/10	dr
Modifications	Date	Name

TSSE 623 R-RA

knitter-switch

30 07 63

Page

1/1