

Actuator 0

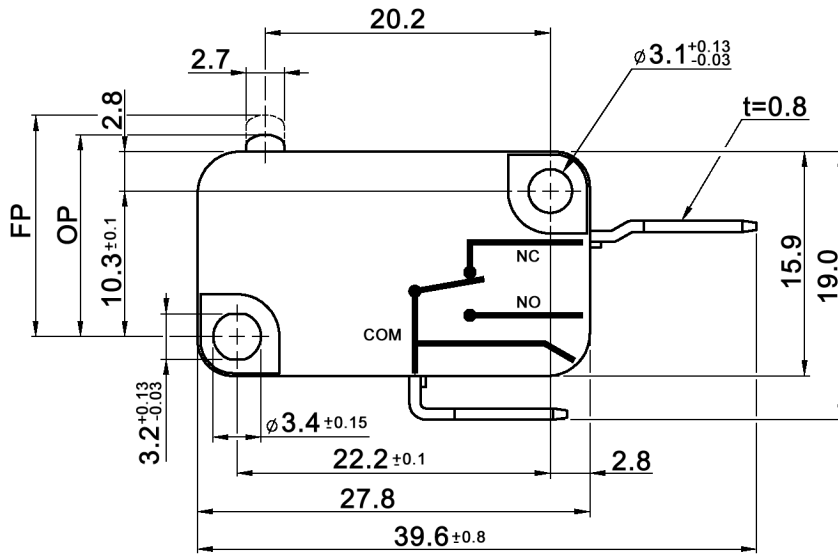

Actuator 1

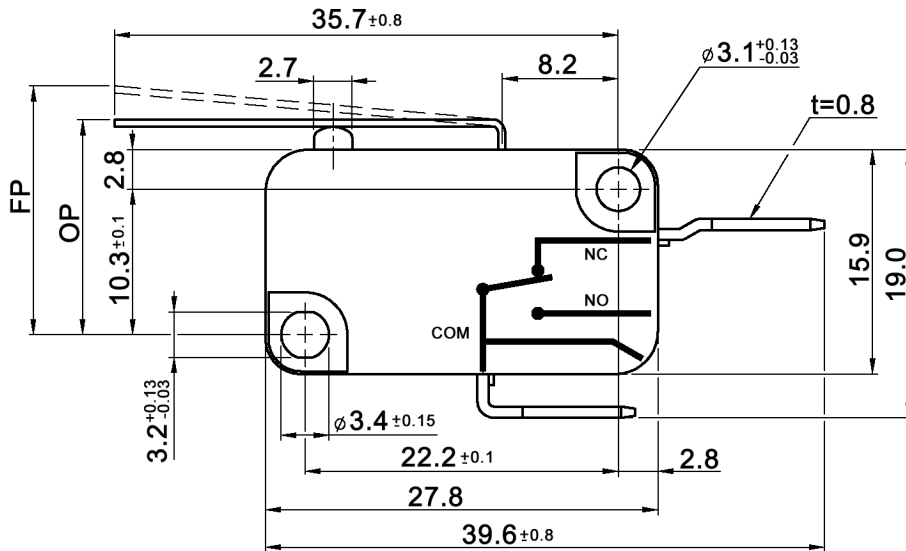

Tolerances: 0.2-30.0: ±0.2mm 30.1-60.0: ±0.3mm	Date	Name
	08/10	dr
Modifications	Date	Name

TMV Actuator

knitter-switch

30 21 59

Page

1/3

Actuator 4

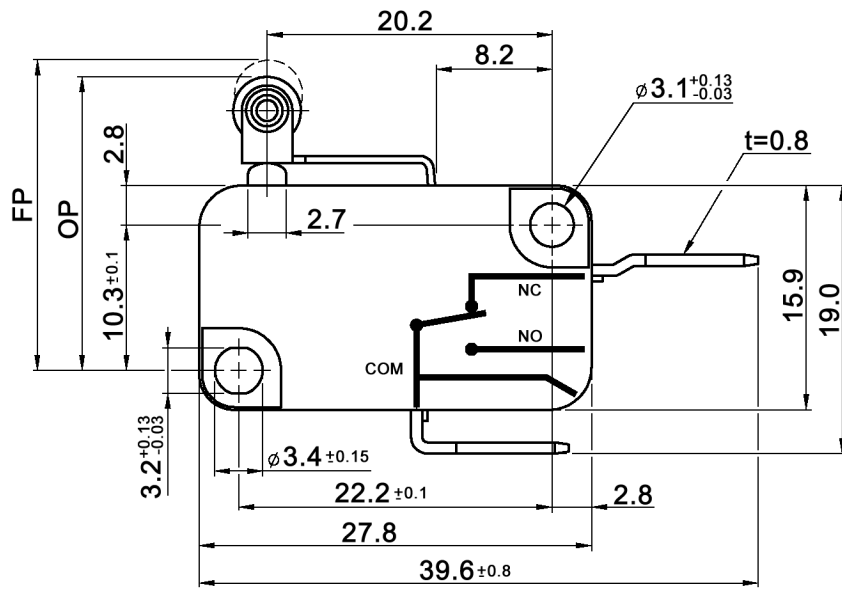

Actuator 5

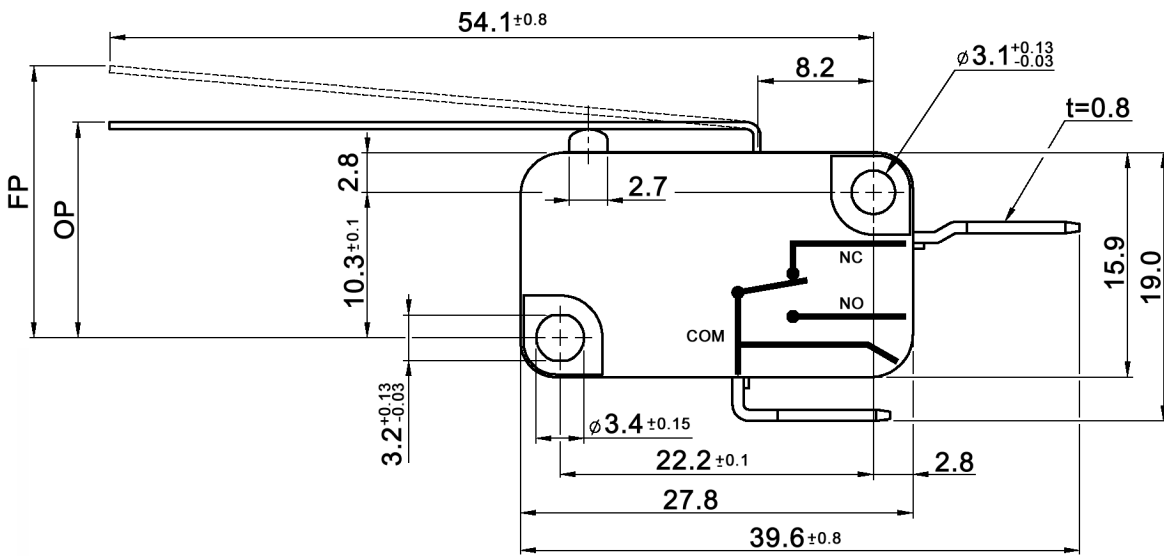

Actuator	Operation force [gf]	Free position [mm]	Operation position [mm]
0	200	16.1±0.5	14.7±0.5
1	125	19.2±1.2	15.2±1.2
2	200	16.8±0.5	15.2±0.5
3	125	24.7±1.2	20.7±1.2
4	240	22.3±0.6	20.7±0.6
5	70	24.2±2.5	15.2±2.5



Tolerances: 0.2-30.0: ±0.2mm 30.1-60.0: ±0.3mm	Date	Name
	08/10	dr

TMV Actuator

knitter-switch

30 21 59

Page

3/3

Modifications	Date	Name
---------------	------	------