

P.C.B. DIMENSION

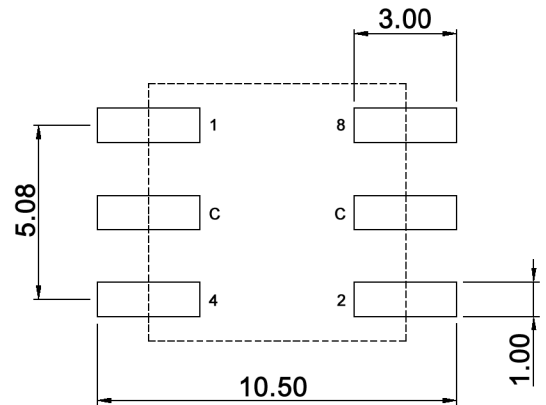

Hexadecimal inverse

	Complement coded				
	C	1	2	4	8
0	●	●	●	●	●
1	●		●	●	●
2	●	●		●	●
3	●			●	●
4	●	●	●		●
5	●		●		●
6	●	●			●
7	●				●
8	●	●	●	●	
9	●		●	●	
A	●	●		●	
B	●			●	
C	●	●	●		
D	●		●		
E	●	●			
F	●				



Tolerances:			Date	Name
			10/08	dr
Packaging	05/10	dr		
Soldering conditions	10/09	dr		
Material	05/09	dr		
Modifications	Date	Name		

SMR 16116 T

knitter-switch

30 16 23

Page

1/3

**Specifications:**

**Contact rating:** non-switching: 400mA, 42V  
switching: 100mA, 42V  
**Contact resistance:** 80mOhm max.  
**Insulation resistance:** 100MOhm min. at 250V DC for 1 minute +/-5sec.  
**Dielectric strength:** 250V DC (50Hz/60Hz) for 1 minute  
**Operating temperature:** -50°C to +125°C  
**Storage temperature:** -55°C to +135°C  
**Mechanical life:** 25 000 cycles  
**Operating force:** 120 +/-30gf/cm  
**Packaging unit:** 600 pcs / reel  
**Material:** Cover / spring plate / guide plate: stainless steel  
Contact / terminal: phosphor bronze, min. 0.07µm gold plated  
over min. 0.3µm nickel  
Rotor / base: LCP, UL94V-0  
O-ring: silicone  
Actuator color: ivory

**Protection:** IP67  
**Soldering conditions:**

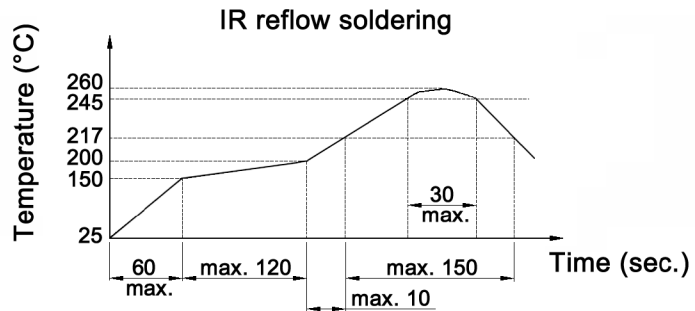

Tolerances:			Date	Name	<b>SMR 16116 T</b>
			10/08	dr	
			<b>knitter-switch</b>		<b>30 16 23</b>
Modifications			Date	Name	Page 2/3

Packaging:

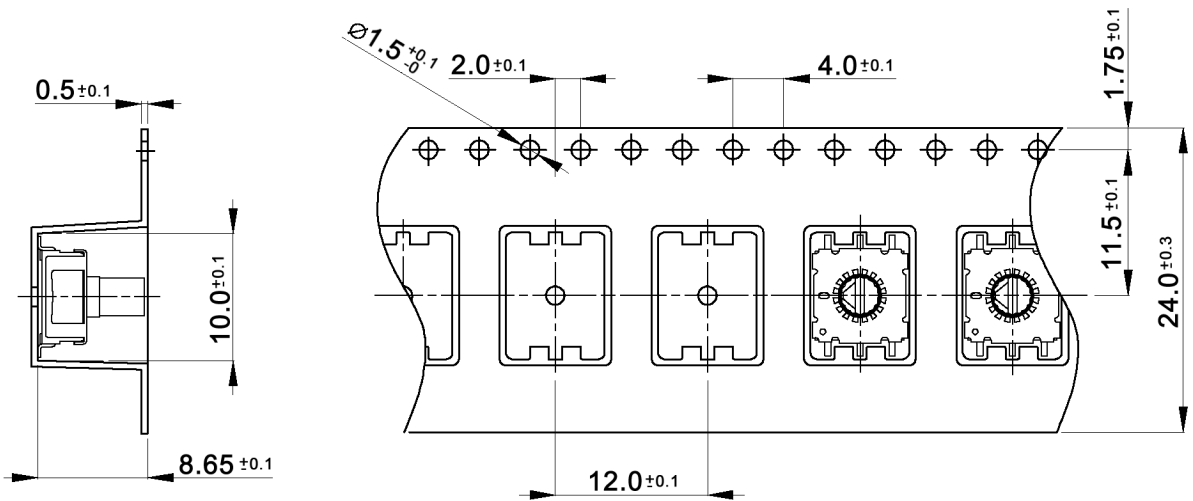
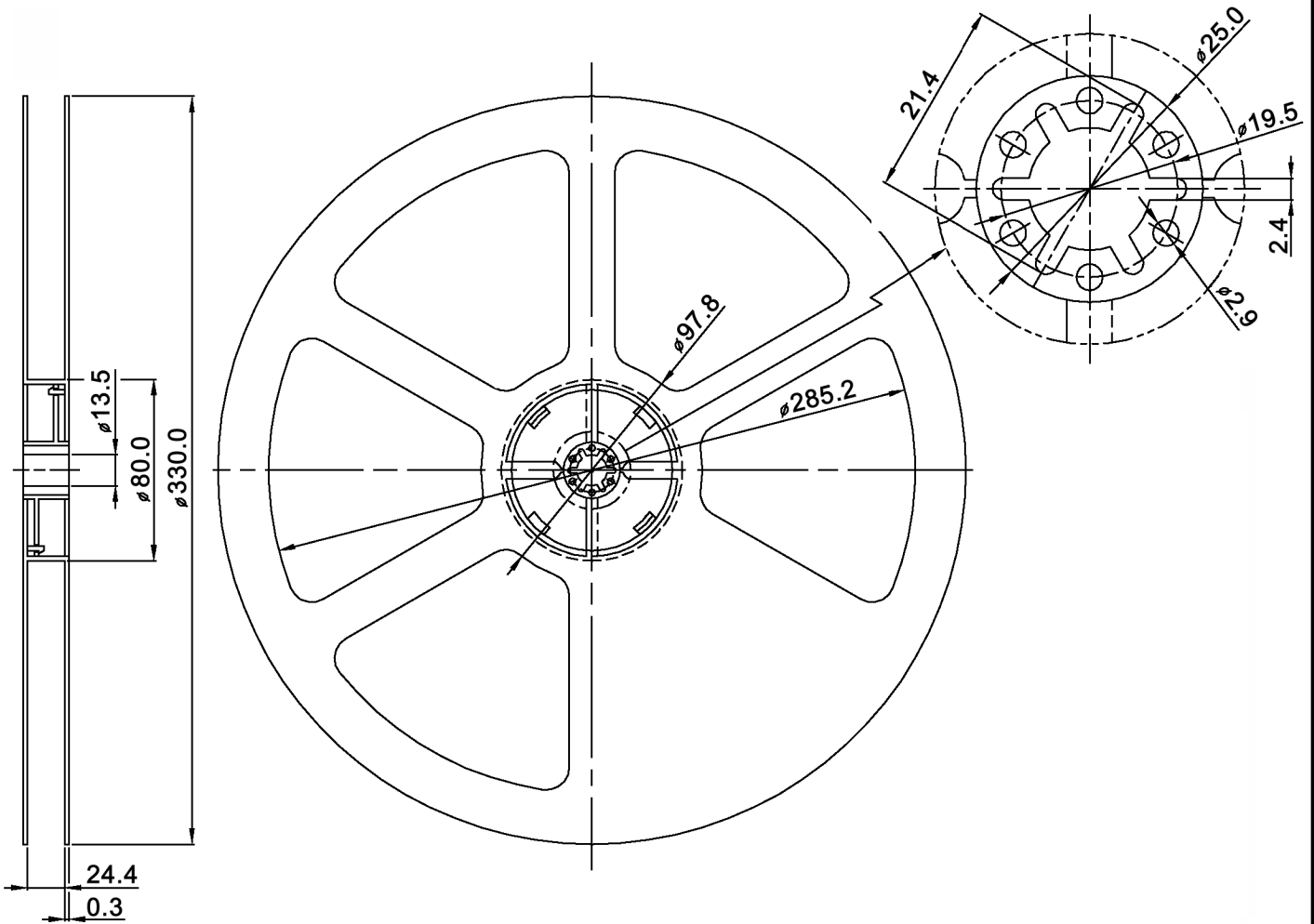

Packaging unit: 600 pcs. / reel



Tolerances:			Date	Name
			05/10	dr
Modifications	Date	Name		

**SMR 16116 T**

**knitter-switch**

**30 16 23**

Page

3/3