

P.C.B. LAYOUT

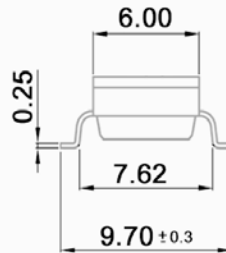
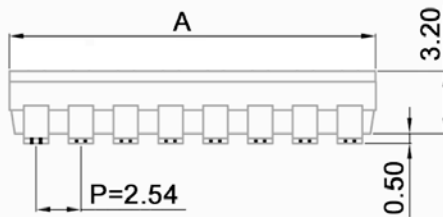
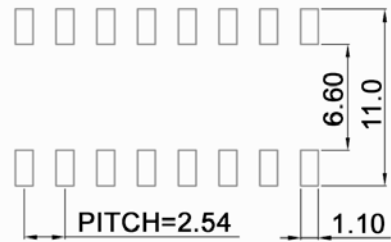

PART No.	POLE	A ±0.2
SBS 9001 TK-ON-N.F.	1	2.98
SBS 9002 TK-ON-N.F.	2	5.52
SBS 9003 TK-ON-N.F.	3	8.06
SBS 9004 TK-ON-N.F.	4	10.60
SBS 9005 TK-ON-N.F.	5	13.14
SBS 9006 TK-ON-N.F.	6	15.68
SBS 9007 TK-ON-N.F.	7	18.22
SBS 9008 TK-ON-N.F.	8	20.76
SBS 9009 TK-ON-N.F.	9	23.30
SBS 9010 TK-ON-N.F.	10	25.84
SBS 9012 TK-ON-N.F.	12	30.92

Specifications:

Contact rating: 25mA, 24V DC
 Non-switching rating: 100mA, 50V DC
 Contact resistance: 50mOhm max.
 Insulation resistance: 100MOhm min. at 500V DC
 Dielectric strength: 500V DC for 1 minute
 Mechanical life: 5 000 cycles
 Operating temperature: -40°C to +85°C
 Storage temperature: -40°C to +85°C

RoHS compliant

Material: Cover: PPS UL94V-0, black
 Base: PPS UL94V-0, black
 Actuator: PA46 UL94V-0, white
 Terminal contact: brass, tin plated
 Movable contact: copper alloy, tin plated
 Terminal: brass, tin plated

Maßstab		Datum	Name	SBS 9000 TK-ON-N.F.
Oberfläche		08/06	dr	
				30 09 53
			knitter-switch	Blatt
	Actuator	03/09	dr	1/3
Zust	Änderung	Datum	Name	

SOLDERING PROFILE:

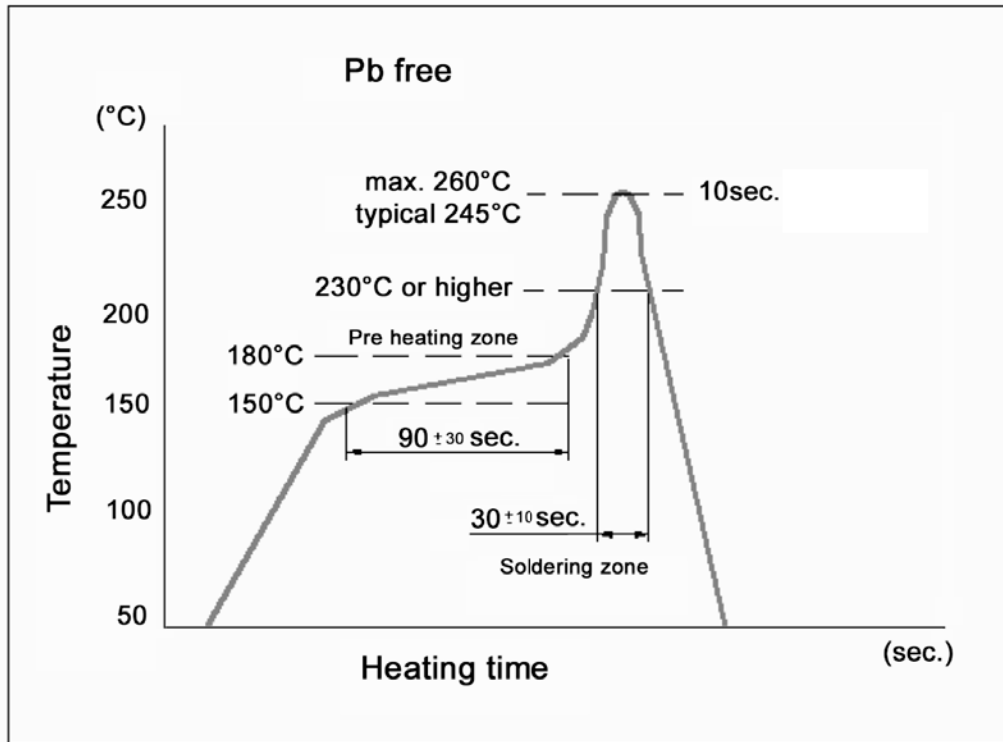

Maßstab		Datum	Name	SBS 9000 TK-ON-N.F.
Oberfläche		08/06	dr	
				30 09 53
			knitter-switch	Blatt
				2/3
Zust	Änderung	Datum	Name	

Taping specification:

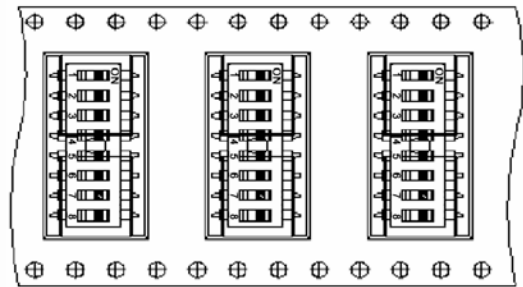
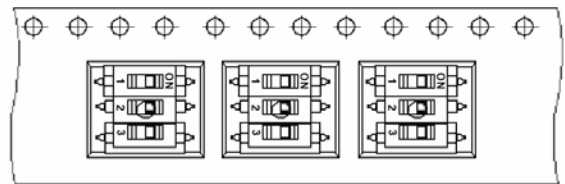
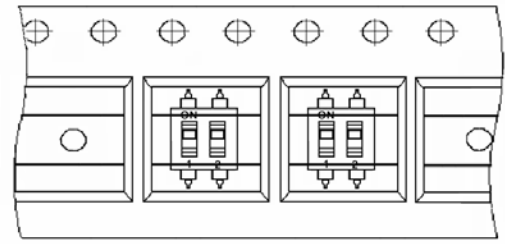
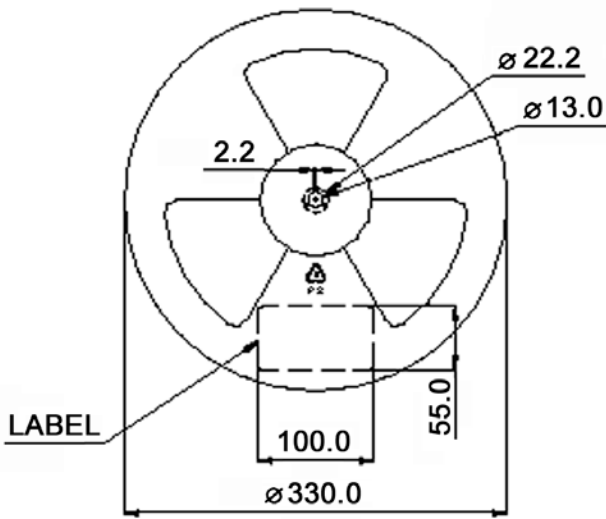

13 INCH
DIAMETER REEL

CONDUCTIVE
PLASTIC EMBOSSED
TAPE

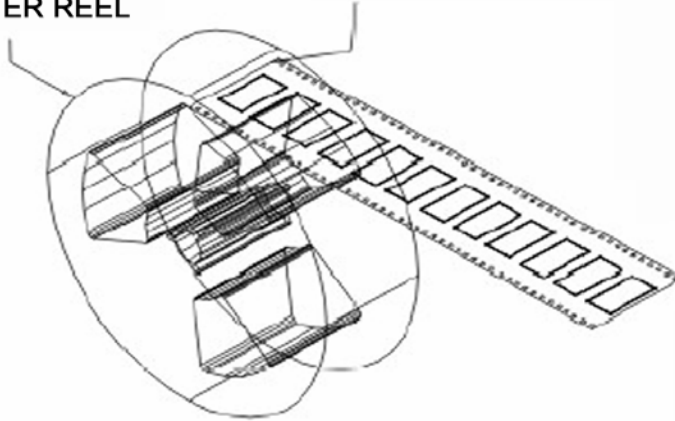

Part No.	Pcs. per reel	Carrier pitch	Carrier width
SBS 9002 TK-ON-N.F.	2000	8	16
SBS 9003 TK-ON-N.F.	1000	16	16
SBS 9004 TK-ON-N.F.	1000	16	24
SBS 9005 TK-ON-N.F.	1000	16	24
SBS 9006 TK-ON-N.F.	1000	16	24
SBS 9007 TK-ON-N.F.	1000	16	32
SBS 9008 TK-ON-N.F.	1000	16	32
SBS 9009 TK-ON-N.F.	1000	16	44
SBS 9010 TK-ON-N.F.	1000	16	44
SBS 9012 TK-ON-N.F.	1000	16	44

Maßstab		Datum	Name
Oberfläche		08/06	dr
Zust	Änderung	Datum	Name

SBS 9000 TK-ON-N.F.

30 09 53

Blatt

3/3

knitter-switch