

P.C. LAYOUT

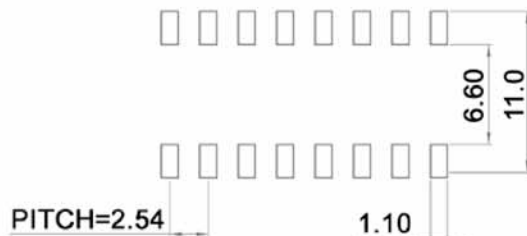

Part No.	A ±0.2
SBP 9202 TK	6.40
SBP 9203 TK	8.94
SBP 9204 TK	11.90
SBP 9205 TK	14.44
SBP 9206 TK	16.98
SBP 9207 TK	19.52
SBP 9208 TK	22.06
SBP 9210 TK	27.14

Specifications:

- Contact rating: 100mA, 50V DC
- Contact resistance: 50mOhm max.
- Insulation resistance: 100MOhm min. at 500V DC
- Dielectric strength: 500V DC for 1 minute
- Operating temperature: -40°C to +85°C
- Storage temperature: -40°C to +85°C
- Mechanical life: 3 000 cycles
- Electrical life: 3 000 cycles
- Operating force: 600g max.
- Resistance to soldering heat: 255 +/-5°C, 5 +/-1sec.

RoHS compliant

Material:

Cover / base: UL94V-0, thermal polyester plus 25-30% glassfiber, black
 Actuators: UL94V-0, thermal polyester plus 5-30% glassfiber, white
 Movable contacts: copper alloy, tin plated
 Terminal / contact: copper alloy, tin plated

Maßstab		Datum	Name
Oberfläche		12/05	rs
Taping spec.	01/06	dr	knitter-switch
Soldering profile	01/06	dr	
Zust	Änderung	Datum	Name

SBP 9200 TK

30 07 45

Blatt

1/3

Soldering profile:

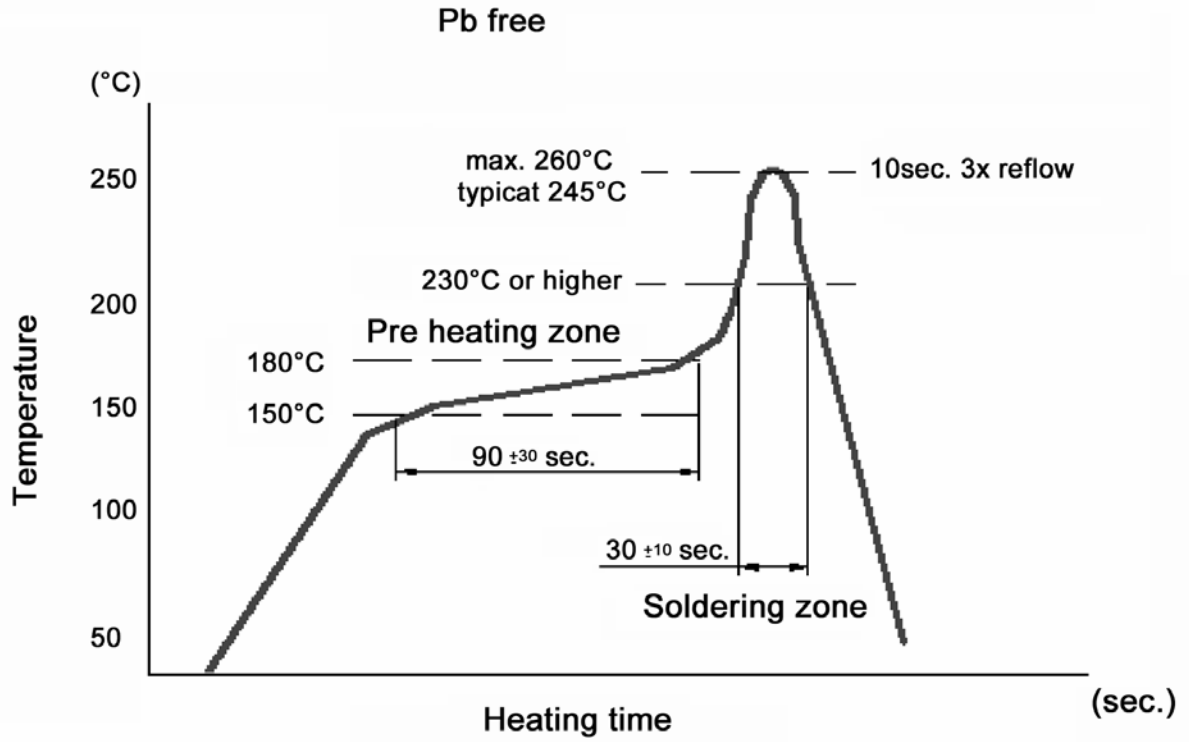

Maßstab		Datum		Name		SBP 9200 TK	
Oberfläche		12/05		rs			
						30 07 45	
		knitter-switch				Blatt	
						2/3	
Zust	Änderung	Datum	Name				

Taping specification:

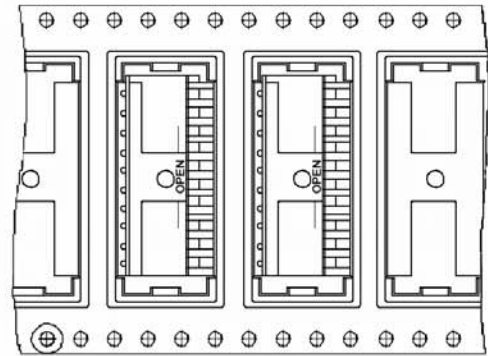
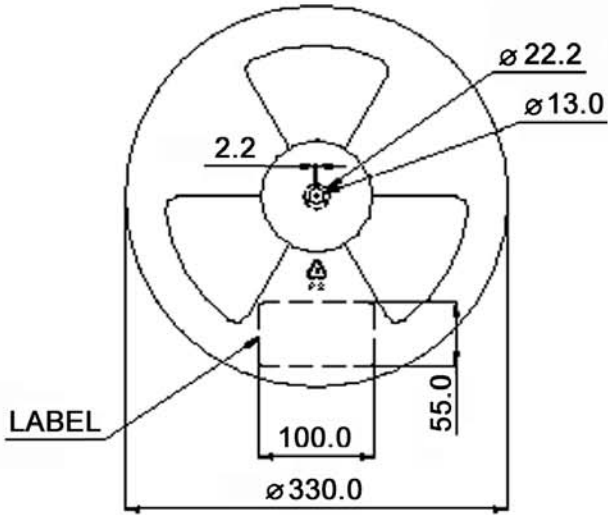

13 INCH
DIAMETER REEL

CONDUCTIVE
PLASTIC EMBOSSED
TAPE

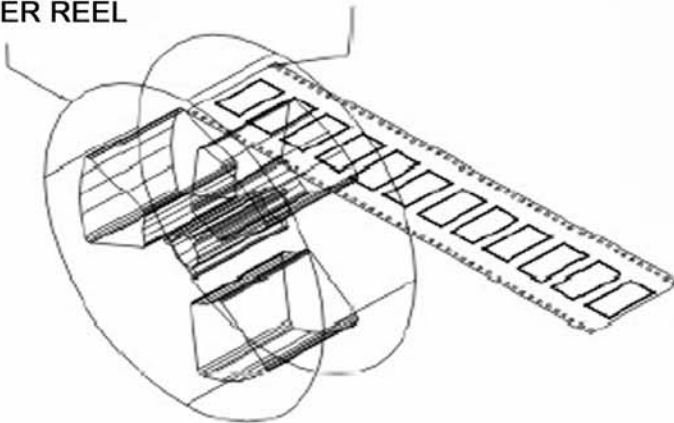

Part No.	Pcs. per reel	Carrier pitch	Carrier width
SBP 9202 T	700	12	24
SBP 9203 T	500	16	24
SBP 9204 T	500	16	24
SBP 9205 T	500	16	24
SBP 9206 T	500	16	24
SBP 9207 T	500	16	44
SBP 9208 T	500	16	44
SBP 9210 T	500	16	44

Maßstab	Datum	Name	
Oberfläche	12/05	rs	
Zust	Änderung	Datum	Name

SBP 9200 TK

30 07 45

Blatt
3/3

knitter-switch