

HOLE LAYOUT
TOP VIEW ± 0.05

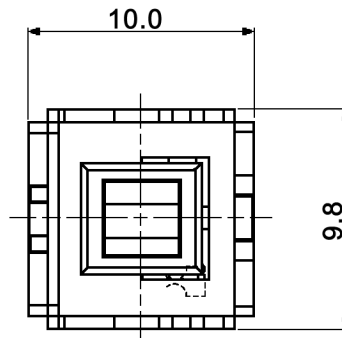

CIRCUIT DIAGRAM
C: COMMON PIN
BOTTOM VIEW

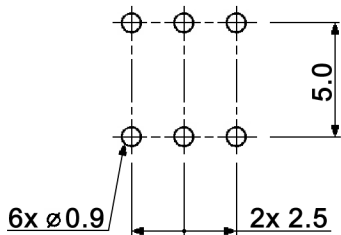
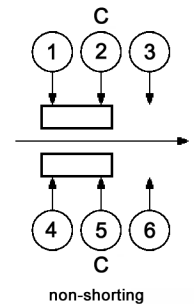

Specifications:

- Contact rating: 0.1A, 30V DC
- Contact resistance: 30mOhm max.
- Insulation resistance: 100MOhm min at 250V DC for 1 minute
- Dielectric strength: 250V AC (50/60Hz, 2mA) for 1 minute
- Operating temperature: -10°C to +60°C
- Mechanical life: 10 000 cycles
- Operating force: 220 +/-80gf
- Soldering conditions: wave soldering: 260°C max., 5sec. max.; pre-heat: 100°C max., 60sec. max.

- Material:
- Spring wire: stainless steel, washing
 - Terminal: brass, silver plated
 - Contact clip: phosphor bronze, silver plated
 - Cover: POM, black
 - Case: PBT, black



Tolerances: up to 10: ±0.2mm above 10-50: ±0.3mm	Date	Name
	10/10	dr
Soldering conditions	10/10	dr
Modifications	Date	Name

MPSA 22D18L-O

knitter-switch

30 21 85

Page

1/1