

Specifications:

Contact rating: 10mA, 5V DC
 Contact resistance: 100mOhm max.
 Insulation resistance: 100MOhm min. at 250V DC
 Dielectric strength: 300V AC for 1 minute
 Operating temperature: -40°C to +85°C
 Storage temperature: -40°C to +85°C
 Rotational life: 15 000 cycles
 Resolution: 20 pulses
 No. of detents: no detents
 Soldering conditions: 260 +/-5°C, 5 +/-1.0sec.
 Switch: Travel: 0.5^{+0.4}_{-0.3} mm
 Mechanical life: 20 000 cycles
 Operating force: 600 +/-300gf

OUTPUT SIGNAL FORMAT

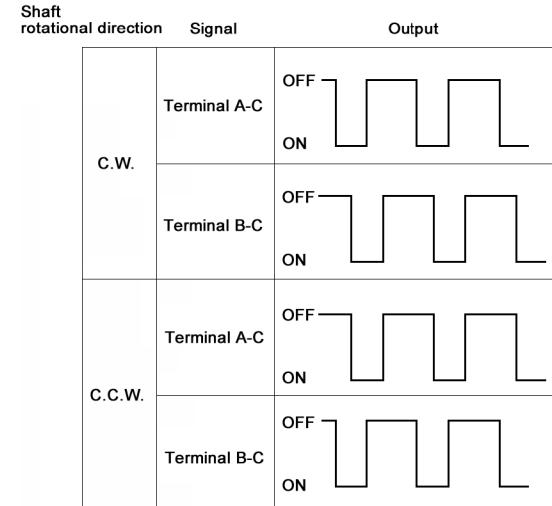

Tolerances: ≤ 10: ±0.3mm 10 - 100: ±0.5mm		Date	Name	MERP11-20N120B
		10/10	dr	
			knitter-switch	30 22 00
Modifications		Date	Name	Page 2/2