

DETAIL "A"

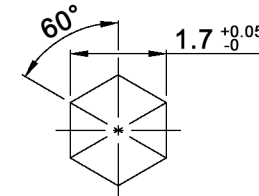

P.C.B. MOUNTING
VIEWED FROM MOUNTING SIDE
t=1.6

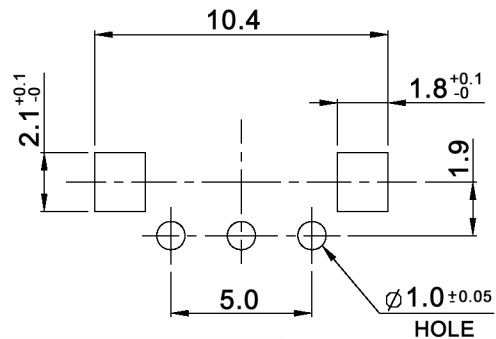

Tolerances: ≤10: ±0.3mm 10-100: ±0.5mm			Date	Name	MER10-12R7
			09/09	dr	
			knitter-switch		30 19 26
Output signal format	04/11	dr			Page
Modifications	Date	Name			1/2

Specifications:

Contact rating: 1mA, 5V DC
 Insulation resistance: 10M Ω min. at 50V DC
 Dielectric strength: 50V AC for 1 minute, 300V AC for 2 sec.
 Operating temperature: -5°C to +45°C
 Storage temperature: -15°C to +65°C
 Rotational life: 100 000 cycles
 Detent torque: 5 +/-3mNm
 No. of pulses: 12 pulses
 Pos. of detent: 24 detents (step angle: 15 +/-3°)
 Soldering conditions: auto-soldering: 260 +/-5°C, 3 +/-1sec.

OUTPUT SIGNAL FORMAT

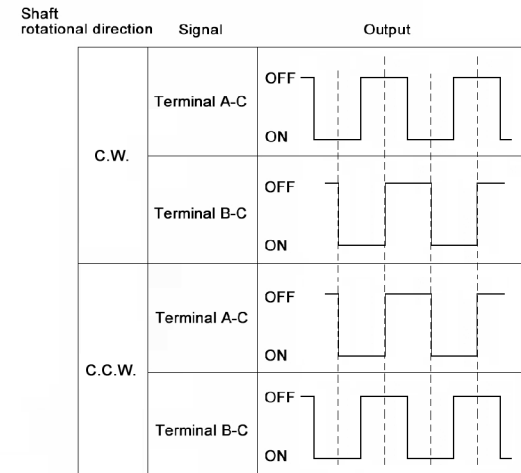

Tolerances: ≤ 10 : ± 0.3 mm 10-100: ± 0.5 mm		Date	Name	<h1>MER10-12R7</h1>
		09/09	dr	
			knitter-switch	<h2>30 19 26</h2>
Modifications		Date	Name	Page 2/2