

Actuator 00

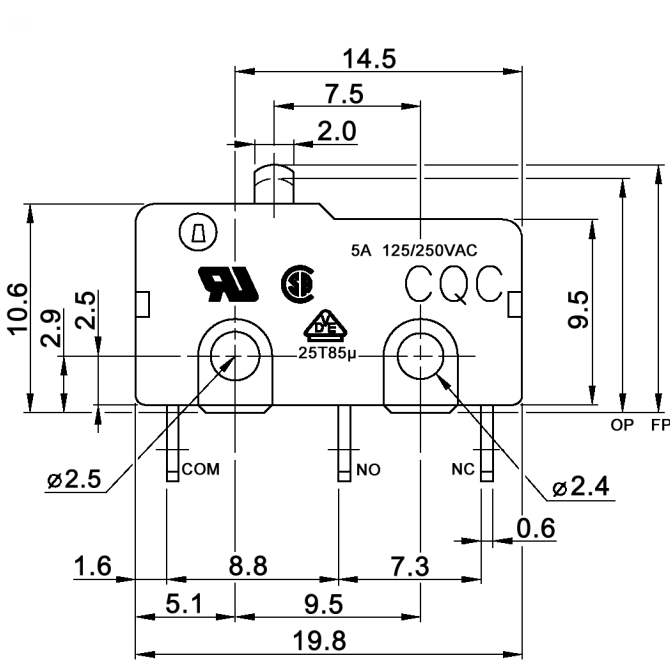

Actuator 01

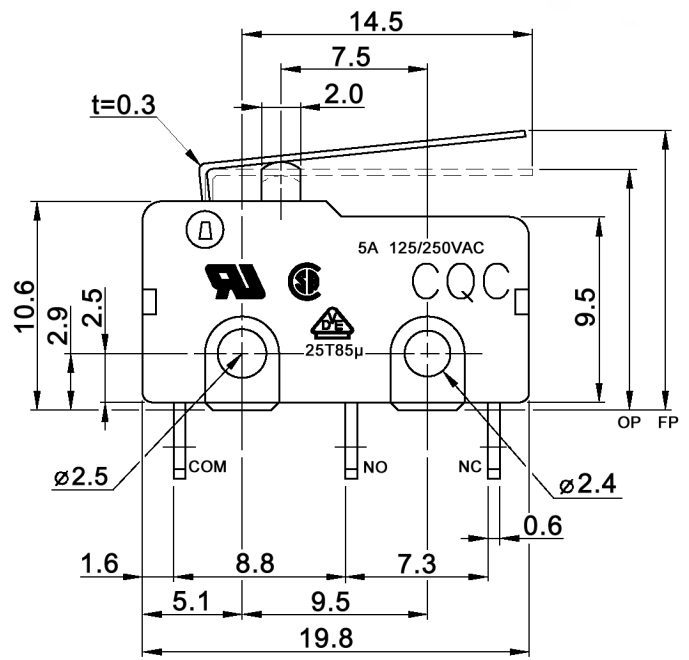

Actuator 02

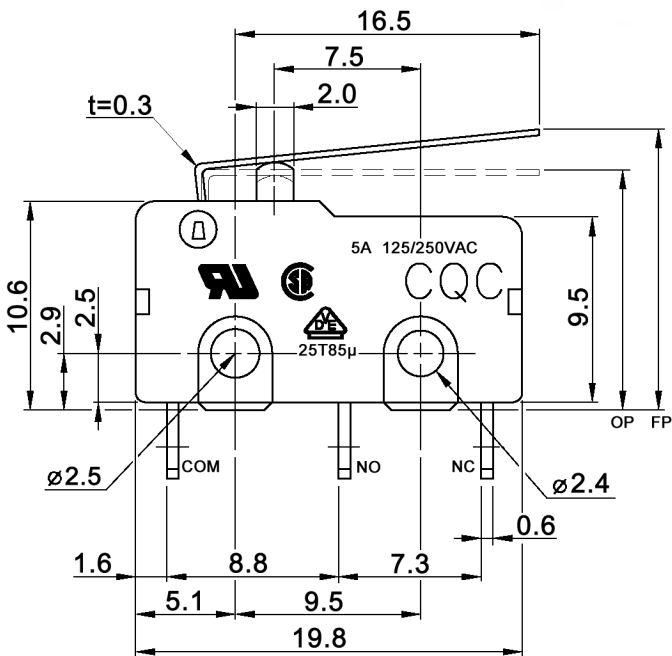

Actuator 03

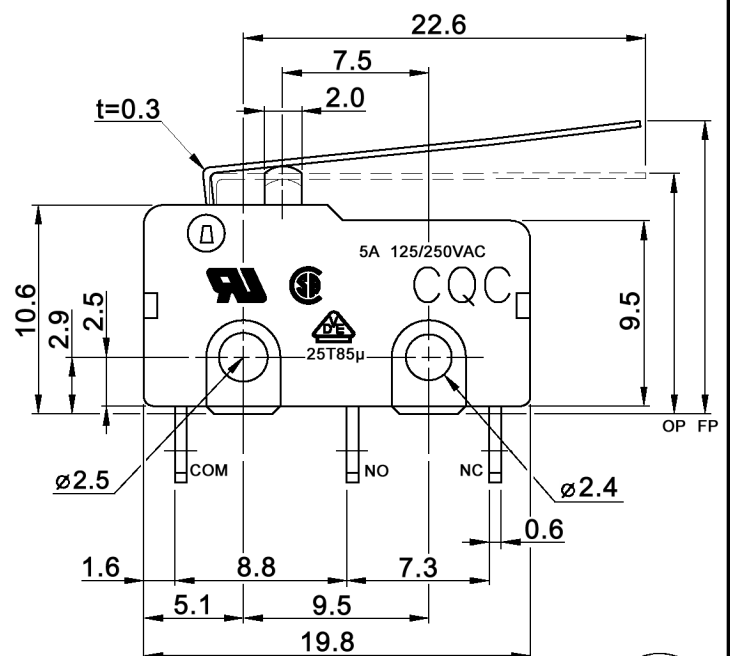

Tolerances: $\pm 0.2\text{mm}$		Date	Name
		08/10	dr
Modifications	Date	Name	

DM-SM Actuator

knitter-switch

30 21 56

Actuator 04

Actuator 05

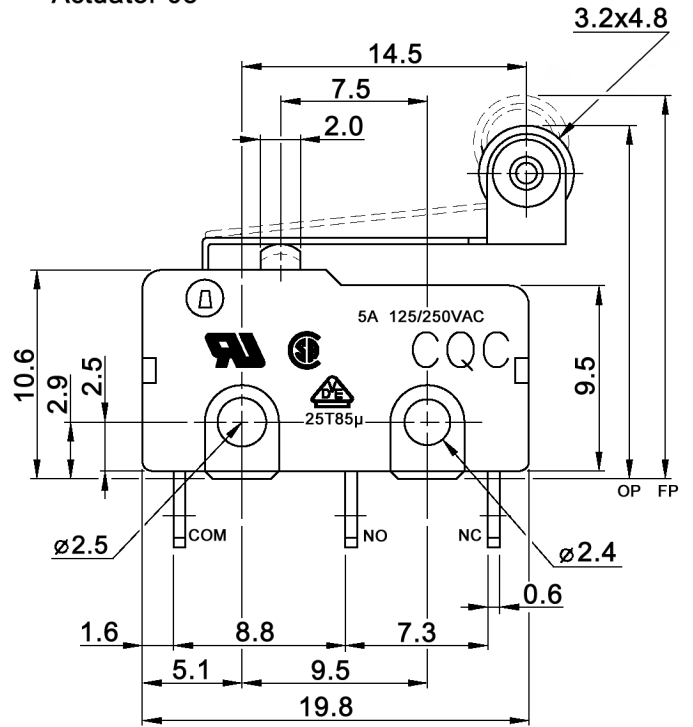
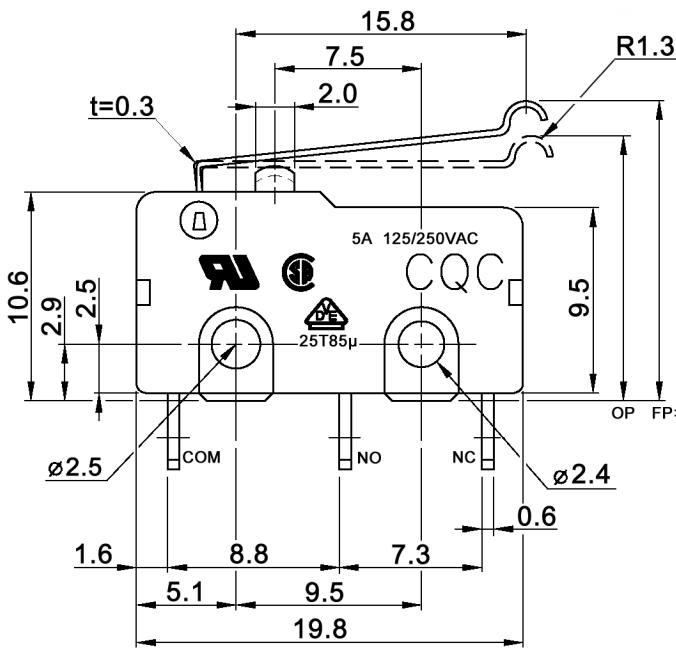

Actuator	Operation force [gf]									Free position [mm]	Operation position [mm]
	80±25	95±30	115±40	130±40	150±40	175±45	190±45	250±50	295±55		
00	80±25	95±30	115±40	130±40	150±40	175±45	190±45	250±50	295±55	11.9±0.3	11.3±0.3
01	25±12	30±12	35±20	40±20	45±20	50±20	55±25	70±25	85±30	14.0±0.8	12.0±0.8
02	20±8	25±12	30±12	35±20	40±20	45±20	50±20	65±25	75±25	14.2±0.8	12.1±0.8
03	15±6	20±6	25±12	30±12	35±20	40±20	55±25	60±25	70±25	15.0±1.0	12.4±0.8
04	20±8	25±12	30±12	35±20	40±20	45±20	50±20	65±25	75±25	16.7±0.8	14.5±0.8
05	20±8	25±12	30±12	35±20	40±20	45±20	50±20	65±25	75±25	219.8±1.0	17.8±1.0



Tolerances: ±0.2mm			Date	Name
			08/10	dr
Modifications	Date	Name		

DM-SM Actuator

knitter-switch

30 21 56

Page

2/2